

## 8. Replacing the chuck

- 8.1 Remove the motor cable 15. To do so unscrew the cap 16 from the motor and loosen the cable by pulling out the plug-in seal 17.
- 8.2 Open the chuck and withdraw the rotary instrument.
- 8.3 Remove sealing cap 24
- 8.4 Use a number 6223 wrench 23 to hold the motor end of the spindle. Insert the chuck tool No. 4115 22. Hold the number 6223 23 wrench tightly and turn the chuck tool anti clockwise to unscrew the chuck completely.  
- the chuck has a right-handed thread!

- 8.5 Clean the chuck, grease it lightly and place it in the spindle. Use the tools to screw the chuck in - clockwise and as far as possible - as described in section 8.4 - and tighten it slightly. Replace the plug-in seal 17 and screw the cap 16 back into place. Replace the sealing cap 24 again.

Please note:

The tools 22 and 23 are to be found in the base of the handpiece rack!

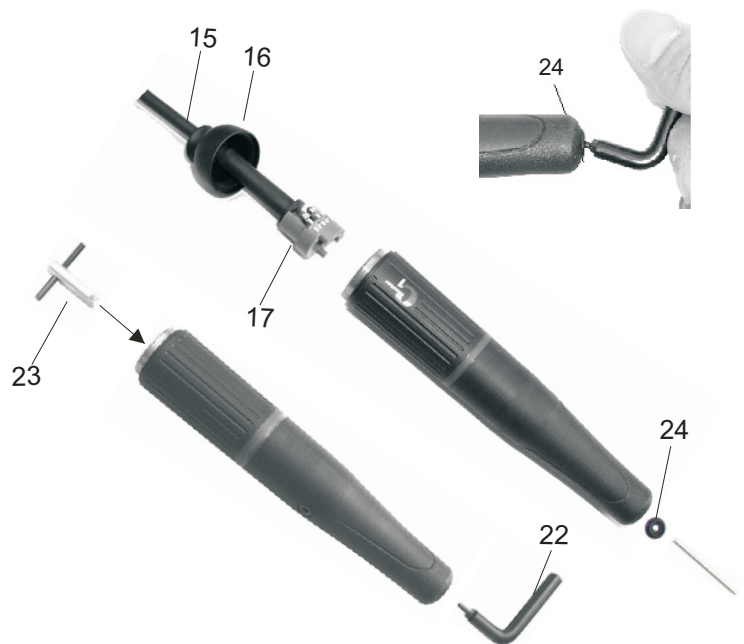
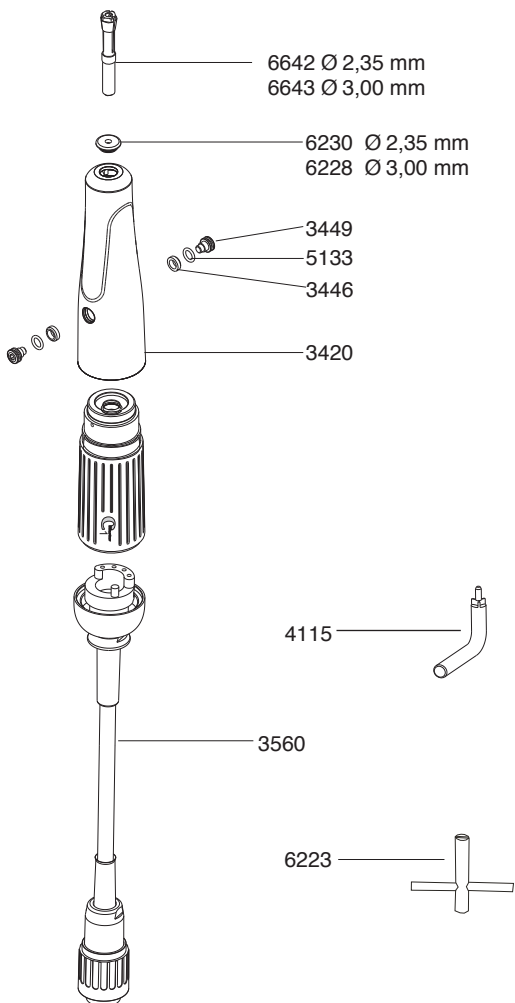

## 9. Care and maintenance

**Caution: Do not clean your C1 Master motorhandpiece with compressed air!**

Chuck: should be cleaned and re-greased once in a while, depending on how dirty it is.

As C1 Master units have no commutators, carbon brushes or ventilation parts, no further maintenance is required.

## 10. Possible faults

Should the handpiece be overloaded, respectively, jammed, for safety reasons the unit will switch itself off.

- Release knee/foot switch and operate it again; the unit is ready for use immediately

bench controller version only

- When using the bench version without a pedal switch, the speed control knob should be turned to "0", when the desired speed is selected again; the unit is ready for use immediately.

- When using the bench version with a pedal switch it should be released and operated again; the unit is then ready for use again.

all versions

if the unit should not be running after doing as described above the 2 fuses have to be checked and eventually exchanged.

The fuses (2x T2AH250V/2x T4AH100V-115V) are to be found at the rear of the unit beneath the socket 1.